

# OUTDOOR THERAPY

EDITION  
2022

EDITION 2022

OUTDOOR THERAPY

**Varaschin**  
OUTDOOR THERAPY

[varaschin.it](http://varaschin.it)

**Varaschin**  
OUTDOOR THERAPY

**Varaschin**  
OUTDOOR THERAPY



## La nostra Visione / Our Vision

“Essere il punto di riferimento in Europa dell’arredo outdoor qualificato. Stimoliamo le persone a vivere in un contesto outdoor che sia il più possibile in simbiosi con la natura e che assicuri un elevato livello di comfort, di benessere e di convivialità. Offriamo un nuovo stile di vita”.

“Be the European benchmark for qualified outdoor furniture. We inspire people to live in an outdoor environment that is as close to nature as possible, and that ensures a high level of comfort, well-being and conviviality. We offer a new lifestyle”.

## Abitare l'esterno / Outdoor Living

Gli arredi da esterni Varaschin testimoniano una specializzazione nell'outdoor che affonda le proprie radici in oltre cinquant'anni di attività, in quell'intreccio manuale che è tecnica e continua ispirazione. Grazie al valore riconosciuto al comfort elevato, vengono studiate e testate proposte che lo assicurano, che richiedono qualità totale, in tutti gli aspetti dell'operare, per far vivere l'ergonomia ogni giorno nel rispetto dei principi del design. Abitare l'esterno diventa l'Outdoor Therapy Varaschin, fedeli alla mission aziendale: "agevolare le persone a vivere bene in un contesto outdoor. Uno stile di vita che consente di essere rilassati, sereni e che permette di raggiungere un benessere psico-fisico ideale. Qualità outdoor."

Varaschin outdoor furniture testifies to a specialization in the outdoors that has its roots in over fifty years of activity, in that hand weaving that is technical and continuous inspiration. Thanks to the recognized value of high comfort, proposals are studied and tested that ensure it, which require total quality, in all aspects of operation, to make ergonomics live every day in compliance with the principles of design. Outdoor living becomes Outdoor Therapy Varaschin, faithful to the company mission: "to make easier for people to live well in an outdoor environment. A lifestyle that allows you to be relaxed, peaceful and achieve ideal psychological and physical well-being. Outdoor quality. "

## INDICE / INDEX

### Capitoli / Chapters

|  |     |
|--|-----|
| Percorrendo l'entroterra toscano<br>/ Travelling through the Tuscan inland | 8   |
| Respirando il mare del Salento<br>/ Breathing the sea of Salento           | 106 |

### La Collezione / The Collection

|                   |     |
|-------------------|-----|
| emma cross / emma | 16  |
| noss              | 76  |
| plinto            | 120 |
| smart             | 152 |
| cricket           | 164 |
| bahia             | 180 |
| tibidabo          | 190 |

### Categoria / Category

|   |                   |     |
|---|-------------------|-----|
| <b>Sedute e sgabelli</b><br>/ Seating and stools  | emma cross / emma | 16  |
|   | noss              | 76  |
|   | smart             | 152 |
|   | cricket           | 164 |
|   | tibidabo          | 190 |
| <b>Poltrone e divani</b><br>/ Armchairs and sofas | emma cross / emma | 16  |
|   | smart             | 152 |
|   | cricket           | 164 |
|   | tibidabo          | 190 |
| <b>Tavoli</b><br>/ Tables                         | plinto            | 120 |
|   | tibidabo          | 190 |
| <b>Tavoli low</b><br>/ Low Tables                 | emma cross / emma | 16  |
|   | plinto            | 120 |
|   | smart             | 152 |
|   | tibidabo          | 190 |
| <b>Lettini</b><br>/ Sunbeds                       | bahia             | 180 |

**PERCORRENDO**  
**L'ENTROTERRA TOSCANO**  
/ TRAVELLING THROUGH  
THE TUSCAN INLAND





Una giovane sognatrice e il suo bracco. Una vita intensa in città e il desiderio di un luogo accogliente per rigenerarsi, festeggiare con gli amici, pensare in solitudine, passeggiare con pochi intimi e a volte lavorare da remoto, respirando l'aria, i profumi delle stagioni, la lentezza della terra. Il paesaggio è l'elemento fondante dello spazio architettonico. Lo attraversa nel suo asse principale a formare un cannocchiale visivo. Racconta l'ambiente circostante con forme contemporanee dove pieni e vuoti si alternano. L'abitazione interagisce con la propria purezza funzionale come fosse un'estensione del lavoro contadino. Allo stesso modo sa curare, accudire e (r)accogliere chi la vive. Gli arredi outdoor di Varaschin selezionati si confrontano con la cultura del territorio e intrecciano la solida conoscenza delle lavorazioni artigianali alla matita contemporanea del design italiano e internazionale.

A young dreamer and her hound. An intense life in the city and the desire for a welcoming place to regenerate, celebrate with friends, think in solitude, walk with a few close friends and sometimes work remotely, breathing the air, the scents of the seasons, the slowness of the earth. The landscape is the founding element of the architectural space. It crosses it in its main axis to form a visual telescope. It tells the surrounding environment with contemporary forms where solids and voids alternate. The house interacts with its functional purity as if it were an extension of peasant work. In the same way it knows how to take care and welcome those who live it. The selected outdoor furniture by Varaschin is confronted with the culture of the territory and intertwines the solid knowledge of craftsmanship with the contemporary pencil of Italian and international design.











# EMMA CROSS / EMMA

DESIGN MONICA ARMANI

La già ricca collezione Emma accoglie nuovi articoli, un paralume d'arredo, slanciato ed elegante, capienti portavasi e tavolini bassi con piano in HPL, ceramica o imbottito (pouf), tutti accomunati dallo stesso intreccio di corda di fibra sintetica. Emma si integra inoltre con lo sviluppo della collezione Emma Cross. L'alluminio delle strutture propone nove tinte così da sposarsi in raffinati accostamenti con i colori delle corde. Perché l'intreccio manuale trova sempre nuove espressioni, a partire da un know-how coltivato con destrezza. Due collezioni contemporanee grazie a una tecnica sempre rinnovata.

The already rich Emma collection includes new items, a slender and elegant furnishing lampshade, capacious plant pots and low tables with HPL, ceramic or padded tops (poufs), all united by the same intertwining of synthetic fiber rope. Emma also integrates with the development of the Emma Cross collection. The aluminum of the structures offers nine colors that create refined combinations with the colors of the strings. This because hand weaving always finds new expressions, starting from know-how cultivated with skill. Two contemporary collections thanks to an ever-renewed technique.

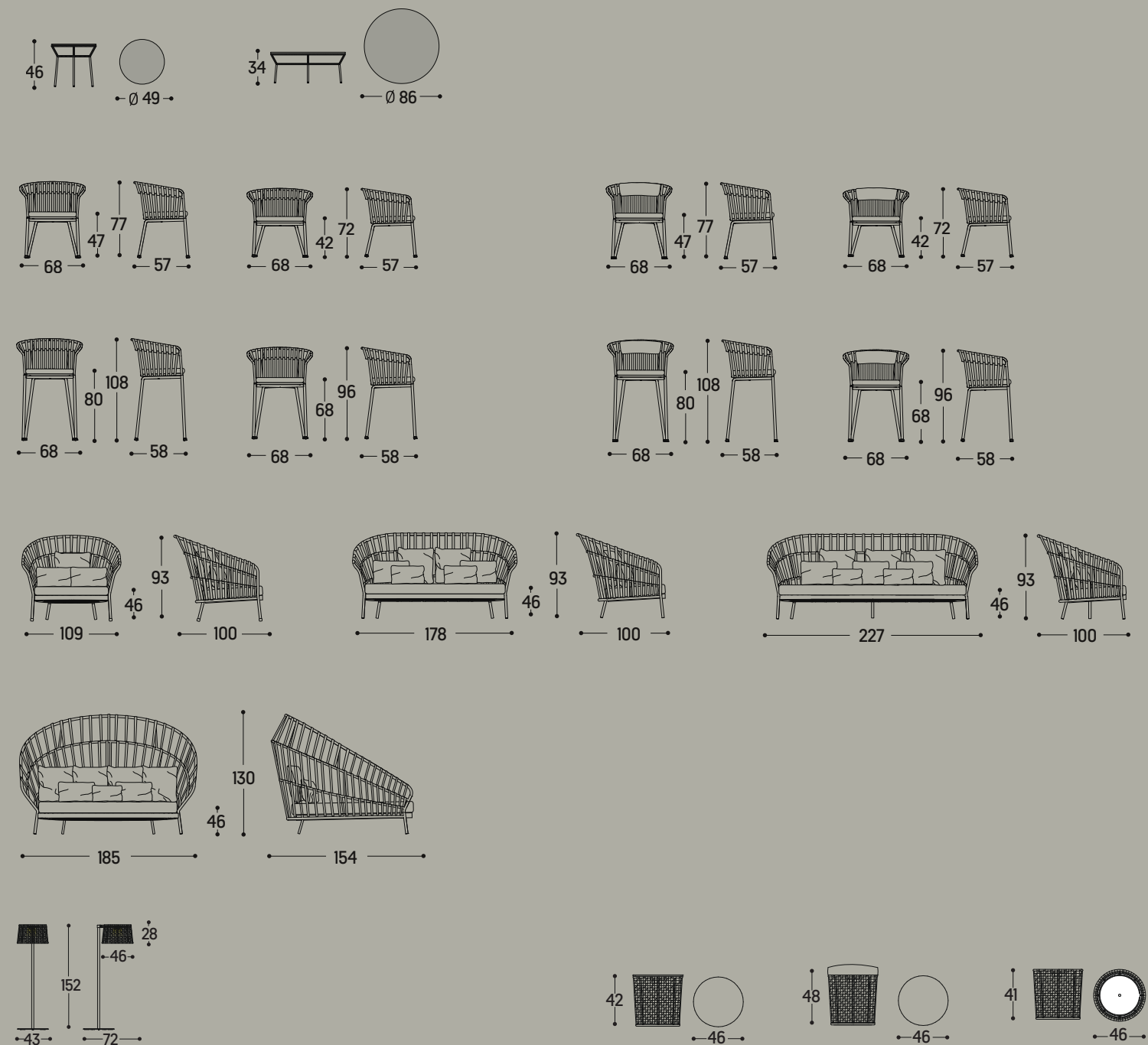

































DIVANO E TAVOLINO EMMA CROSS – FIORIERA E PARASOLE EMMA / EMMA CROSS SOFA AND COFFEE TABLE – EMMA FLOWER POT AND SUNSCREEN





POLTRONA EMMA CROSS / EMMA CROSS ARMCHAIR



FIORIERA EMMA / EMMA FLOWER POT

















































TAVOLINO EMMA – TAVOLINI EMMA CROSS / EMMA COFFEE TABLE – EMMA CROSS COFFEE TABLES































DAYBED E TAVOLINO EMMA CROSS / EMMA CROSS DAYBED AND COFFEE TABLE









# NOSS

DESIGN EDOARDO GHERARDI

Struttura in tubo di alluminio e seduta in lamiera verniciati a polveri in nove finiture definiscono sedia, poltroncina e sgabello, ideali negli spazi pubblici grazie a soluzioni tecniche, facilità di spostamento e ingombro contenuto. Noss è un esempio di ricerca progettuale Varaschin: ogni aspetto è fonte di approfondimenti, confronti, scelte, prove e modifiche fino a quando ciascuno degli artefici può dirsi soddisfatto come se lo avesse fatto per sé, senza riserve.

Structure in aluminum tube and seat in powder coated sheet metal in nine finishes define the chair, armchair and stool, ideal in public spaces thanks to technical solutions, ease of movement and small footprint. Noss is an example of Varaschin design research: every aspect is a source of insights, comparisons, choices, tests and modifications until each of the creators can be satisfied as if they had done it for themselves, without reservations.

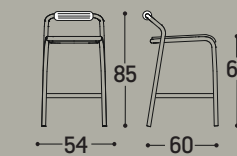
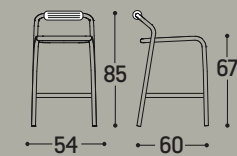
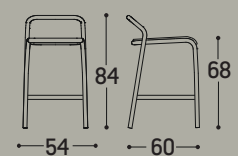
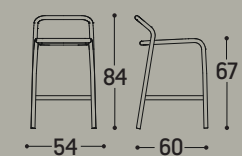
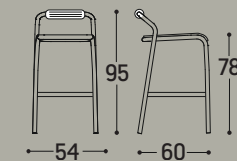
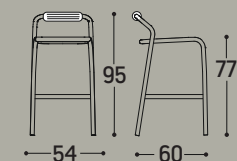
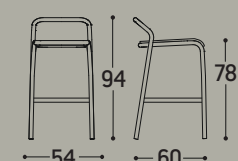
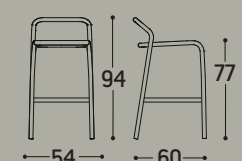
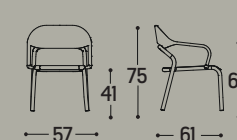
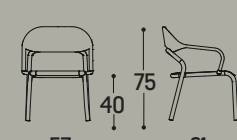
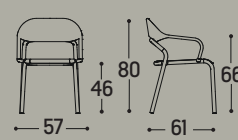
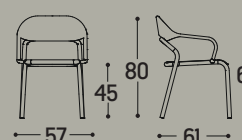
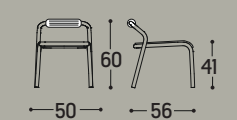
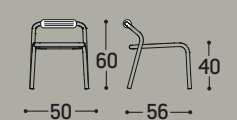
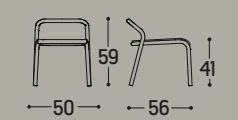
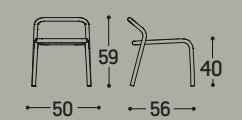
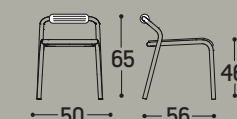
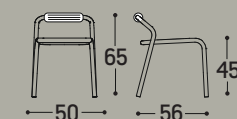
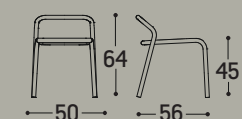















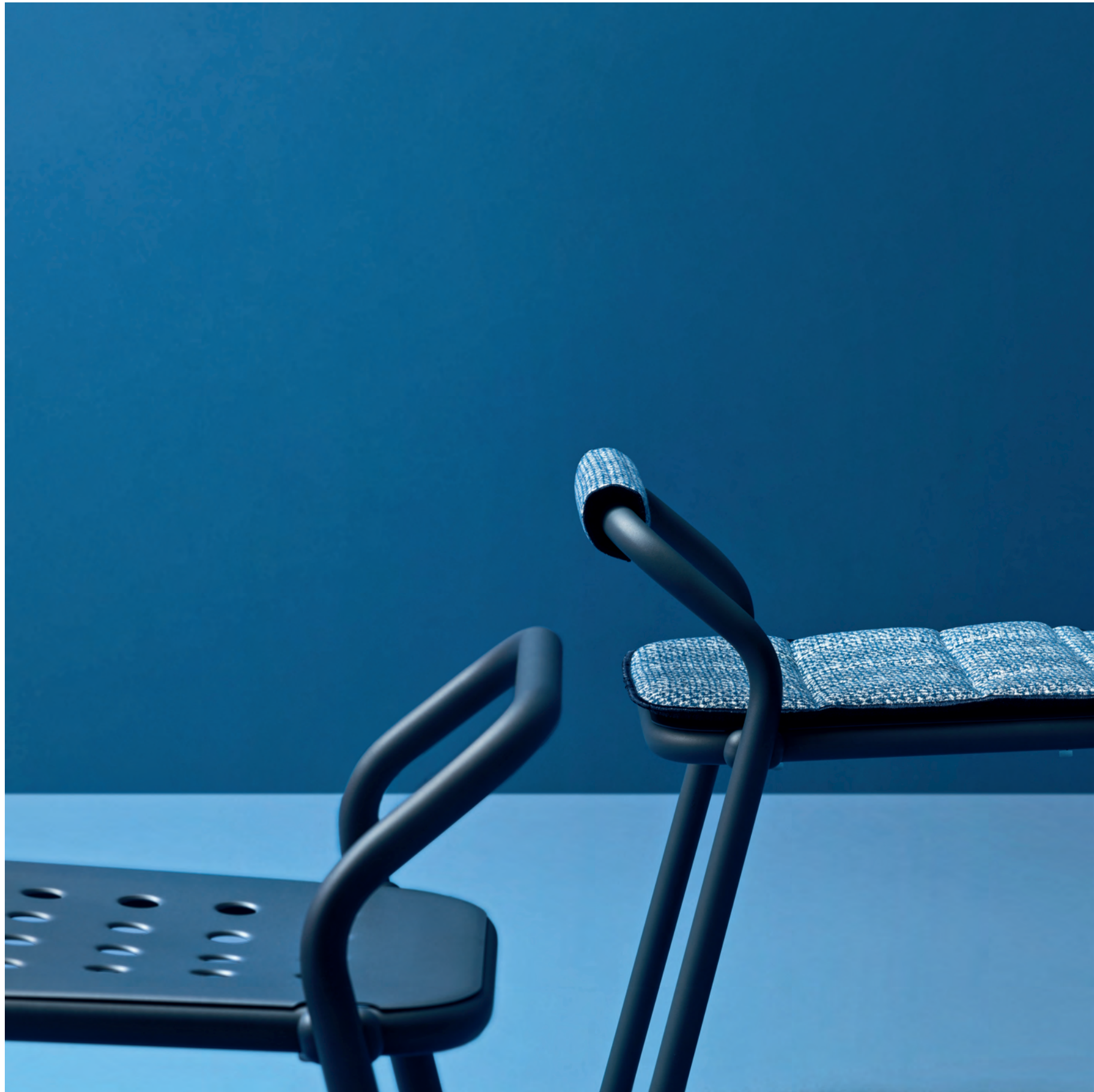









SEDIE EASY NOSS / EASY NOSS CHAIRS







SEDIE EASY NOSS / EASY NOSS CHAIRS





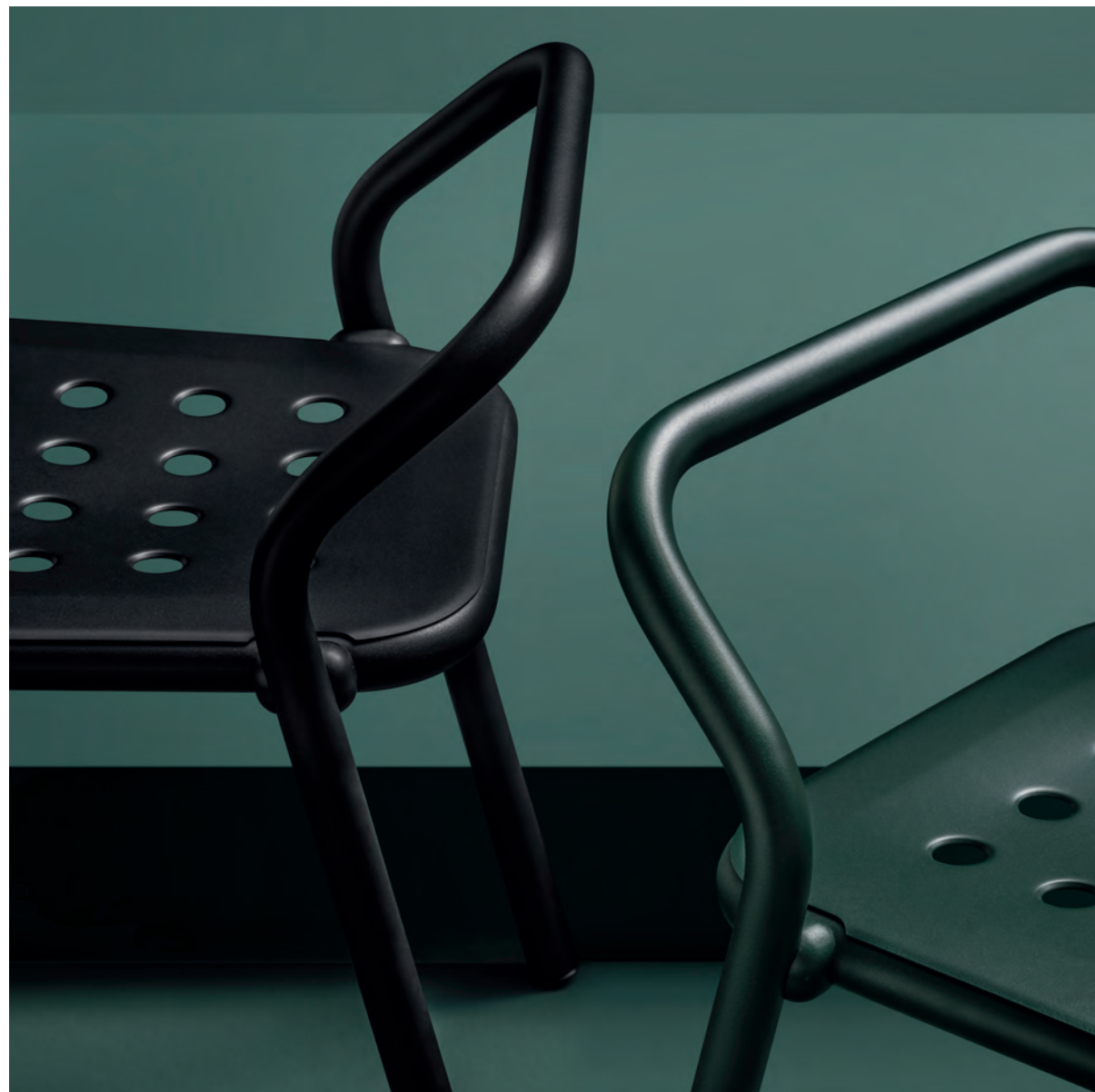





















POLTRONCINE NOSS / NOSS DINING ARMCHAIRS









**RESPIRANDO IL MARE  
DEL SALENTO**  
/ BREATHING THE SEA  
OF SALENTO





Vivere la quotidianità in coppia a pochi chilometri dal mare, nella campagna pugliese. Una masseria recuperata che dimostra attenzione per la tradizione mediterranea, le sue suggestioni, i suoi materiali. Il colore abbagliante della calce viva, la polvere della terra, i muretti a secco, le distese di ulivi. Al loro servizio, gli arredi outdoor di Varaschin traducono quella predisposizione all'accoglienza, tipica del luogo, in forme ergonomiche e materiali durevoli, che garantiscono il comfort più elevato.

Live everyday life as a couple just a few kilometers from the sea, in the Apulian countryside. A recovered farm that shows attention to the Mediterranean tradition, its suggestions, its materials. The dazzling color of quicklime, the dust of the earth, the dry stone walls, the expanses of olive trees. At their service, Varaschin's outdoor furniture translates that welcoming attitude, typical of the place, into ergonomic shapes and durable materials, which guarantee the highest comfort.























# PLINTO

DESIGN PIO E TITO TOSO

Un design ispirato alla natura e alla bellezza, attento alla funzionalità e dedicato a basi per tavoli ergonomiche. Offrono infatti la giusta stabilità, accompagnano con la forma l'uso e danno spazio al movimento di chi siede. Un'armonia che permette di introdurre un tavolo in grado di accogliere comodamente fino a otto persone e Sit & Eat Plinto, corpo unico in alluminio che integra seduta e tavolo in HPL, completo di gancio portaborsa e di due piedini con ruote che ne facilitano lo spostamento. L'interazione fra chi vive un luogo, il luogo stesso e gli arredi che usa può essere perfetta, se sa creare i giusti equilibri. È sinergia fra gli elementi.

A design inspired by nature and beauty, attentive to functionality and dedicated to ergonomic table bases. In fact, they offer the right stability, accompany the use with the shape and give space to the movement of those who sit. A harmony that allows you to introduce a table that can comfortably accommodate up to eight people and Sit & Eat Plinto, a single aluminum body that integrates seat and table in HPL, complete with bag hook and two feet with wheels that facilitate its shift. The interaction between those who live in a place, the place itself and the furnishings can be perfect, if they know how to create the right balance. It is synergy between the elements.

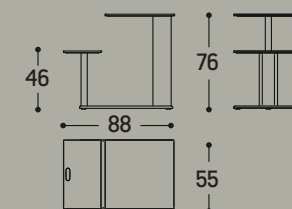
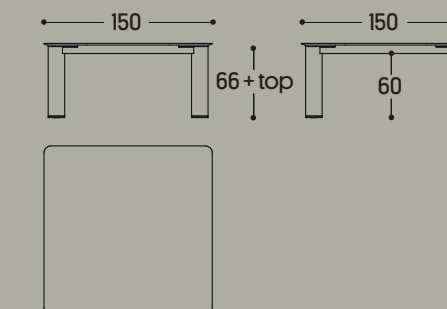
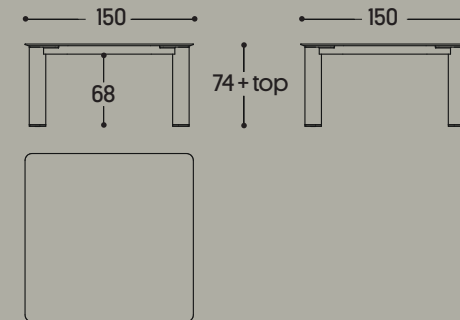
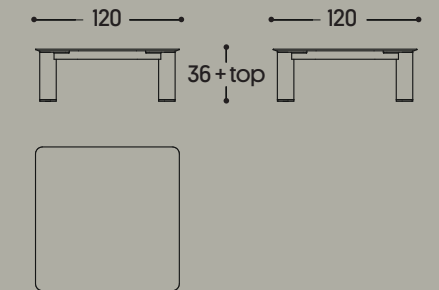
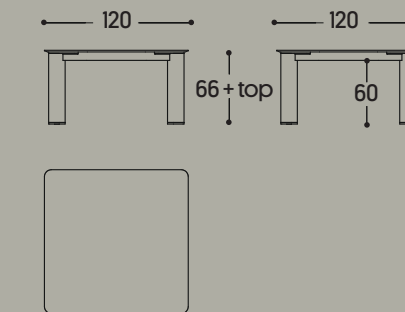
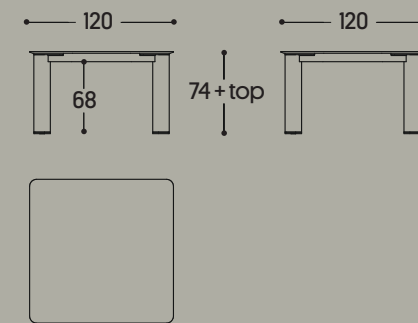
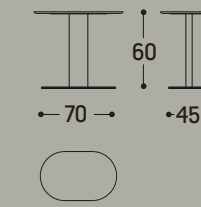
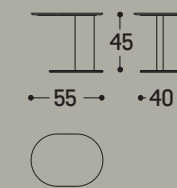

































TAVOLO PLINTO – SEDIE EASY NOSS / PLINTO TABLE – EASY NOSS CHAIRS































SIT & EAT PLINTO / PLINTO SIT & EAT





# SMART

DESIGN R&D VARASCHIN

Smart è la collezione di sedute Varaschin - divano, dondolo, poltrona poltroncina e sgabello – più agile, una soluzione di forte interesse. Una nuova finitura bronzo illumina le strutture in alluminio verniciate a polveri, riveste la seduta di tessuto tecnico VAR#TEX bronzo e intreccia il cordino sintetico VAR#TEX bronzo negli schienali. È un altro piccolo tassello vagliato e curato dai designer Varaschin per far vivere al meglio l'arredo.

Smart is the Varaschin seating collection - sofa, rocking chair, armchair and stool - more agile, a solution of great interest. A new bronze finish illuminates the powder-coated aluminum structures, covers the seat in bronze VAR#TEX technical fabric and weaves the bronze VAR#TEX synthetic drawstring into the backrests. It is another small piece examined and curated by the Varaschin designers to get the best out of the furniture.

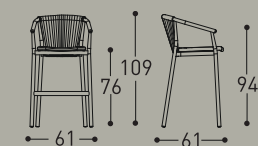
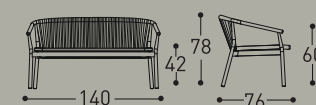
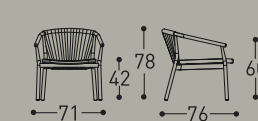
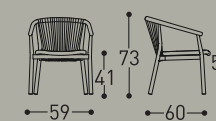
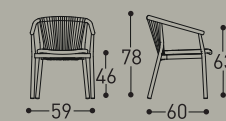























# CRICKET

DESIGN ANKI GNEIB

La pregiata ritorcitura della corda che caratterizza la collezione Cricket intreccia nuovi elementi, una sedia con braccioli impilabile e due differenti paralumi che arredano con la loro stessa presenza. Le lampade sono senza cavi, ricaricabili, con un magnete per fissare i LED luminosi in posizione, perfette per l'outdoor. L'impegno profuso in più di cinque decenni nel progettare arredi da esterni, sempre diversi, migliori e curati, e nel confronto, infondono alla progettualità Varaschin la volontà e la competenza per evolvere.

The precious twisting of the rope that characterizes the Cricket collection intertwines new elements, a stackable chair with armrests and two different lampshades that furnish with their own presence. The lamps are cordless, rechargeable, with a magnet to fix the bright LEDs in place, perfect for the outdoors. The commitment made in more than five decades in designing outdoor furniture, always different, better and more refined, and in comparison, instill the will and competence to evolve in Varaschin's design.

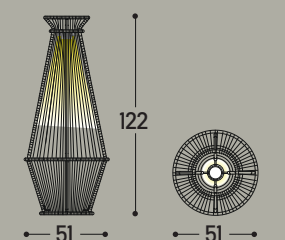
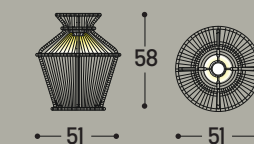
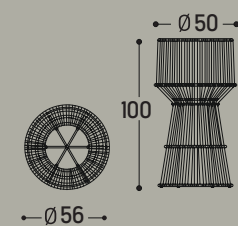
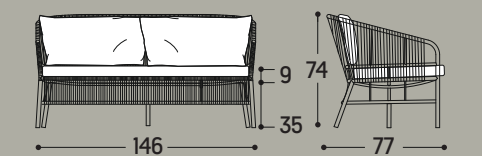
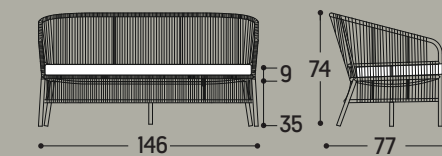
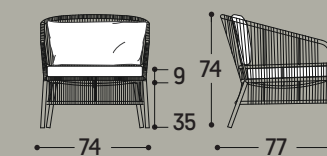
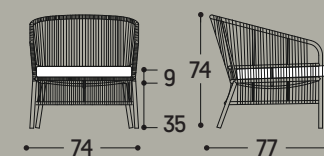
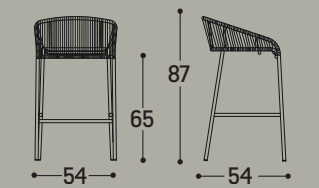
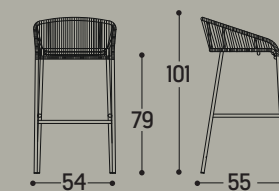
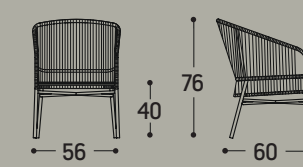
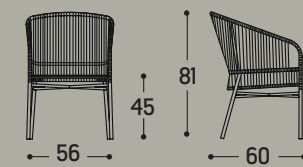
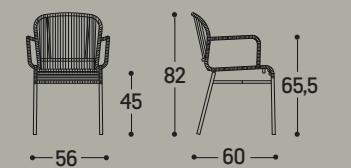
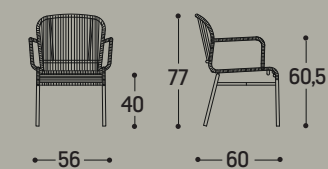
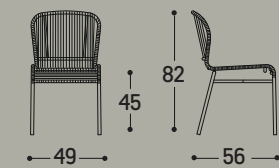









PARALUMI CRICKET / CRICKET LAMPSHADES























# BAHIA

DESIGN CALVI BRAMBILLA

La nuova finitura bronzo arricchisce le scelte per la struttura d'aluminio verniciato a polveri e per le sedute e gli schienali Bahia in VAR#TEX, brevetto Varaschin, resistente agli agenti esterni più aggressivi, come la nebbia salina. È una tinta che introduce una nota calda, di facile utilizzo in contesti outdoor caratterizzati dai toni della terra, del cotto, della sabbia o di pietre che virano dal mattone al porpora. Contribuisce a offrire loro un'estetica rilassante, integrata in modo armonioso nell'ambiente, e così a perseguire il benessere personale di chi utilizza quegli spazi.

The new bronze finish enriches the choices for the powder-coated aluminum structure and for the Bahia seats and backrests in VAR#TEX, a Varaschin patent, resistant to the most aggressive external agents, such as saline fog. It is a color that introduces a warm note, easy to use in outdoor contexts characterized by the tones of the earth, terracotta, sand or stones that turn from brick to purple. It helps to offer them a relaxing aesthetic, harmoniously integrated into the environment, and thus to pursue the personal well-being of those who use those spaces.

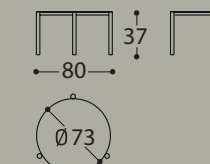
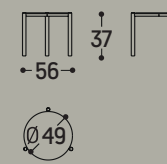
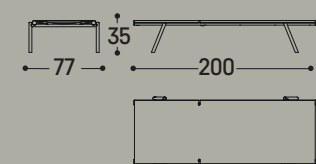









LETTINO E TAVOLINO BAHIA – SDRAI PIEGHEVOLI CLEVER / BAHIA SUNLOUNGER AND COFFEE TABLE – CLEVER FOLDABLE DECKCHAIRS













# TIBIDABO

DESIGN CALVI BAMBILLA

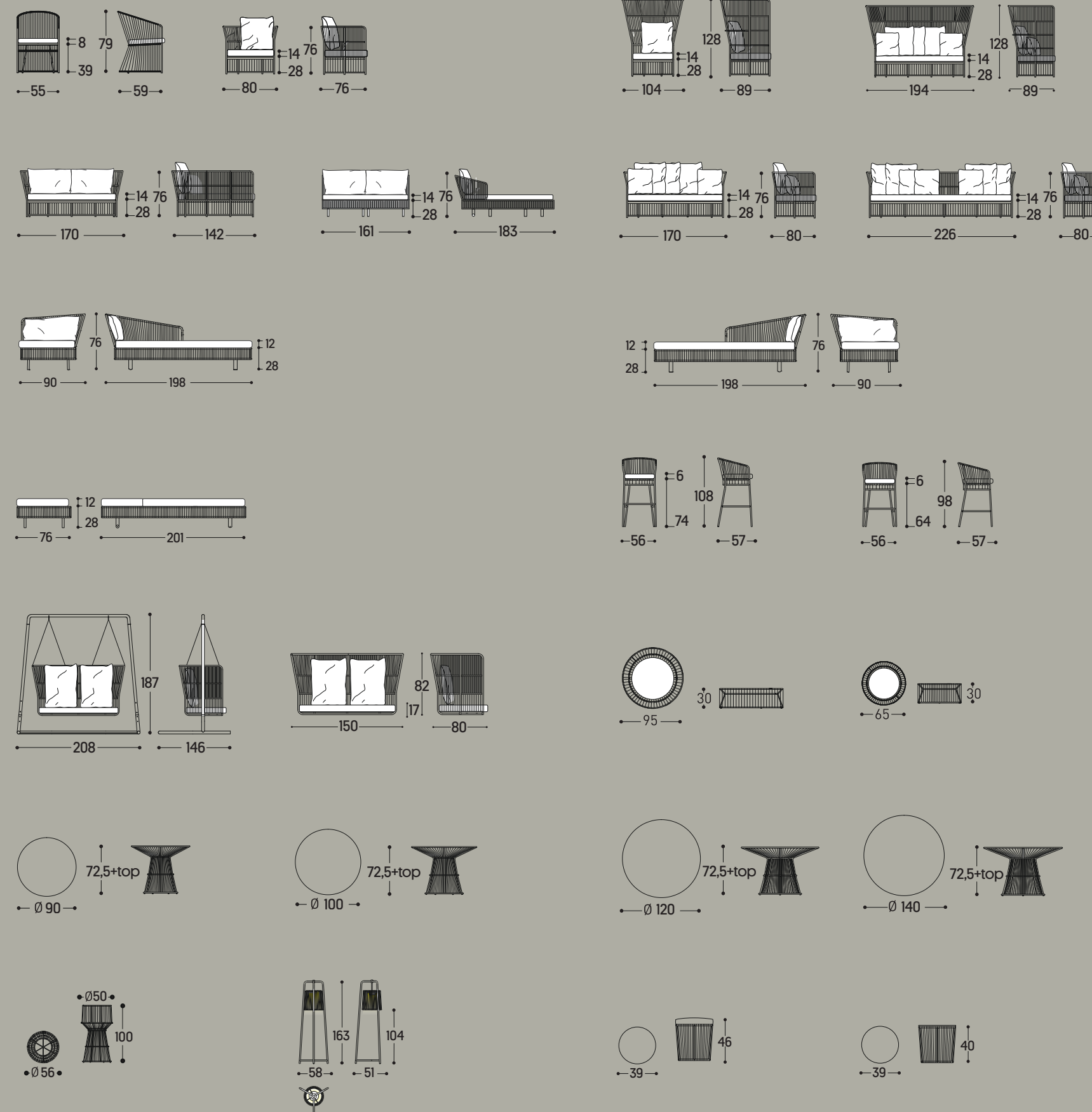

Tibidabo, già programma di arredo outdoor completo come pochi, si arricchisce di un paralume R&S Varaschin che cattura la vista con la sua mole leggera di tubi d'alluminio e corda di fibra sintetica. È pratico, senza cavi e ricaricabile, come l'altro nuovo corpo illuminante con cuscino imbottito, ed è pouf, o con piano top, ed è tavolino. Entrambi esaltano l'intreccio con la luce soffusa che si diffonde in eleganti trame luminose. Raccontano come la preziosità del fatto a mano Varaschin dischiuda opportunità uniche da coltivare, originate dal know-how maturato, dalla ricerca, dall'innovazione di forme, disegni e materiali.

Tibidabo, already a complete outdoor furniture program like few others, is enriched with a lampshade R&D Varaschin that catches the eye with its light mass of aluminum tubes and synthetic fiber rope. It is practical, without cables and rechargeable, like the other new luminaire with padded cushion, and it is a pouf, or with a top, and it is a coffee table. Both enhance the intertwining with the soft light that spreads in elegant luminous textures. They tell how the preciousness of the handmade Varaschin opens up unique opportunities to cultivate, originating from the know-how, matured from research, innovation of shapes, designs and materials.



















**UNA FILOSOFIA  
IN CUI SI INTRECCIANO  
VALORI DISTINTIVI**

**A PHILOSOPHY  
IN WHICH DISTINCTIVE  
VALUES INTERTWINE**



## INTRECCIO MANUALE / HAND WEAVING

Tra i tratti caratteristici delle nostre collezioni c'è da sempre l'intreccio manuale, inizialmente realizzato con fibre naturali e oggi con materiali sintetici in grado di garantire grande durevolezza senza rinunciare alla leggerezza. Viene eseguito seguendo la lezione della tradizione e infondendovi le nuove forme di bellezza che esige il presente. / Among the iconic features of our collections there has always been hand weaving, initially made with natural fibers and today with synthetic materials able to guarantee great durability without sacrificing lightness. It is carried out following the traditional techniques and infusing the new forms of beauty that modernity demands.





## COMFORT ELEVATO / ELEVATED COMFORT

Il comfort è al centro di tutte le nostre azioni e riflessioni. Spingerlo ai massimi livelli, garantire a chi sceglie Varaschin soluzioni che non si limitino ad appagare lo sguardo ma che offrano autentica comodità e predispongano al sentirsi a proprio agio anche attraverso la scelta dei materiali e dei colori è la promessa che da sempre ci impegniamo a mantenere. / Comfort is at the core of all our actions and thinking. Taking it to the highest levels, guaranteeing to those who choose Varaschin not only harmony in design but also authentic comfort and a predisposition to feeling at ease also through the choice of materials and colors. A promise that we have always been committed to keeping.





## QUALITÀ TOTALE / TOTAL QUALITY

Qualità significa per noi qualità di ogni aspetto del nostro operare. Dei materiali in funzione della durevolezza. Dei processi produttivi per offrire un'accuratezza che fa la differenza e si apprezza in ogni minimo dettaglio del prodotto finito. E anche del servizio, certo, perché scegliere Varaschin equivale ad affidarsi a un vero e proprio partner. / Quality means a guarantee in each aspect of our work. Materials chosen in function of durability. Control of production processes to guarantee the accuracy that makes the difference and can be appreciated in every small detail of the end product. The service, clearly, because choosing Varaschin means relying on a real partner.





## DESIGN

La nostra idea di design si fonda sull'intramontabile binomio forma-funzione. Coniugare estetica e relax è il compito che ci siamo dati e che portiamo avanti trasformando in elementi e complementi di arredo lo stretto rapporto tra benessere della persona e spazio abitativo esterno che contraddistingue la nostra filosofia. / Our concept of design is based on the timeless combination form-function. Bringing together aesthetic and relax is the challenge we have set ourselves and that we bring forth, transforming into furnishing elements and accessories the close relationship between personal well-being and outdoor living that distinguishes our philosophy.





## ERGONOMIA / ERGONOMICS

L'ergonomia è una scienza che sappiamo vestire di stile. I nostri designer progettano pensando innanzitutto alla persona e al suo rapporto effettivo, quotidiano, prolungato con l'elemento di arredo. E il risultato si sente. / Ergonomics is a science that we're able to dress up with style. Our designers think, in the first place, about the person and the daily and prolonged relationship with their furniture. You can perceive final result.





## SPECIALIZZAZIONE OUTDOOR / OUTDOOR SPECILIZATION

Più di cinque decenni trascorsi a fare, ideare, immaginare in funzione dell'arredamento outdoor ci rendono consapevoli della nostra competenza in questo ambito specifico, che è frutto anche di un confronto attento e continuo con l'evoluzione del mercato delle proposte per interni. / More than five decades spent making, conceiving, imagining outdoor furniture make us aware of our expertise in this specific segment, which is also the result of a careful and continuous comparison with the evolution of market in all its expressions.





## Credits

|                |   |
|----------------|---|
| AD             | gherardiarchitetti                            |
| STYLING        | Cora Vohwinkel                                |
| PHOTO LOCATION | Franco Chimenti / Elena Rosignoli [Assistent] |
| PHOTO STUDIO   | Studio Emozioni / Flavio Favero               |
| TEXTS          | Roberta Osso                                  |
| PHOTOLITO      | Luce  |
| STAMPA         | Sincromia, Settembre 2021                     |

## Thanks

|         |   |
|---------|---|
| PROPS   | Society Limonta, Laesse ceramica                    |
| CLOTHES | Être Conceptstore [Pordenone], Mosquito [Pordenone] |



**Varaschin S.p.A.**

via Cervano 20 / 31029  
Vittorio Veneto (TV) Italia

T +39 0438 56 45  
F +39 0438 564 666

[varaschin@varaschin.it](mailto:varaschin@varaschin.it)  
[varaschin.it](http://varaschin.it)